

Web Controller EH-WD10DR/WA23DR

Palm sized All-in-One Controller

HITACHI
Inspire the Next

- Embedded Web server
- E-mail sending function
- ASR message communication
- Self created Web pages can be stored
- Configuration via Web browser
- PLC functionality
- Various serial communication possibilities
- IEC 61131-3 programming
- 32 bit-RISC-processor



Web Controller EH-WD10DR/WA23DR

Palm sized All-in-One Controller

Application Examples

Security

The Web Controller provides a solution for security with a camera and a sensor. When the sensor detects trespassing into the restricted area, the Web Controller instructs a camera to capture a picture and reports to the system administrator.

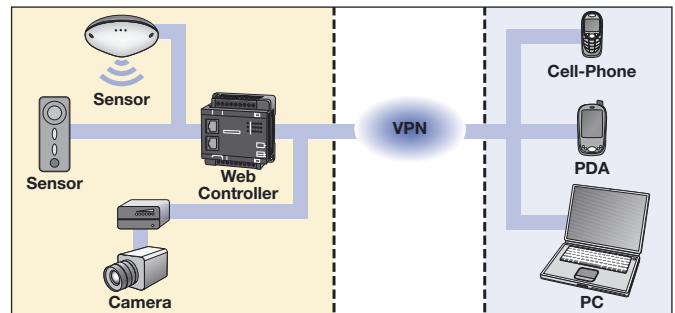

Monitoring and controlling FA equipment

Traditionally special FA networks were prepared and dedicated PC terminals for each network would be necessary, even if just a few points of data were required. By connecting the Web Controller to both a LAN and the equipment, the data can be monitored by any PC connected on that LAN.

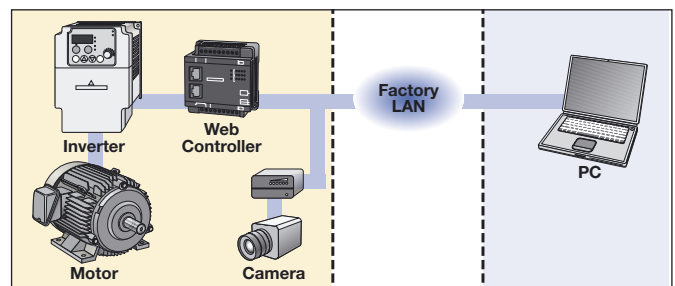

Store automation

The Web Controller can be used as a bi-directional controlling system for stores.

Status of Point of Sales, refrigerators, etc. can be monitored and controlled remotely.

All the stores can be supervised by headquarters, and each store can be monitored by the owner remotely.

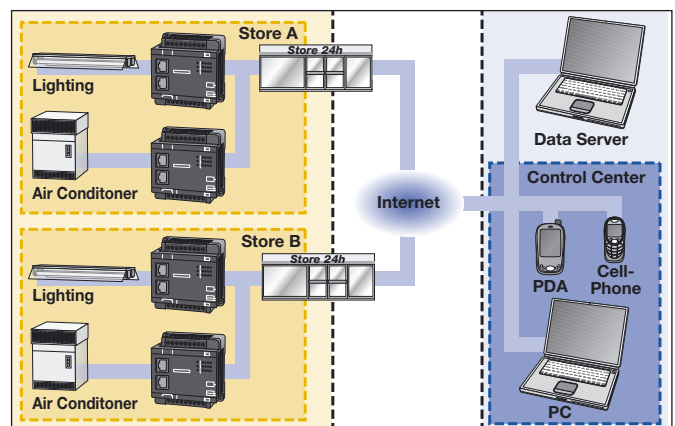

Main Features

The Web Controller is very useful both in an office and the field. Monitoring and controlling have been realized through mobile phones and PDA's. An e-mail can also be sent when an event occurs.

Web Server Function

Data on the Web Controller can be read/written using any PC on a network with an Internet browser. The Web Controller provides a web server functionality using built-in HTTPD ⁽¹⁾ and special CGI ⁽²⁾.

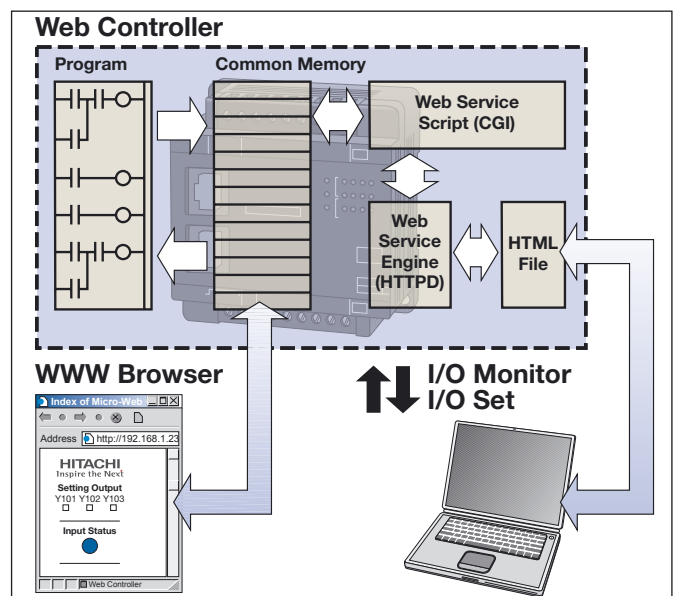

⁽¹⁾ HTTPD: Hyper Text Transfer Protocol Daemon

⁽²⁾ CGI: Common Gateway Interface

Email Sending Function

The Web Controller can send an e-mail by using the built-in SMTP ⁽³⁾.

Up to 16 preconfigured e-mail messages can be automatically sent, based on independent PLC events. Each e-mail contains plain text and max. 3 process data words.

- Max. 8 destination addresses
- Subject, body, data (max. 3 words) can be configured for each condition

⁽³⁾ SMTP: Simple Mail Transfer Protocol

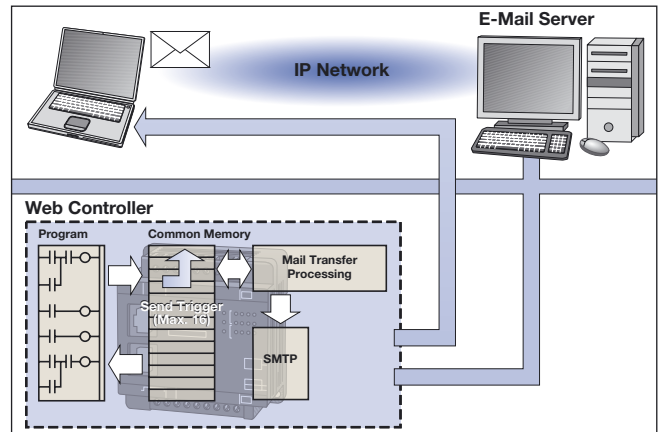

Automatic Data Sending / Receiving Function

Automatic data sending / receiving without user program can be realized once after communication parameters are configured.

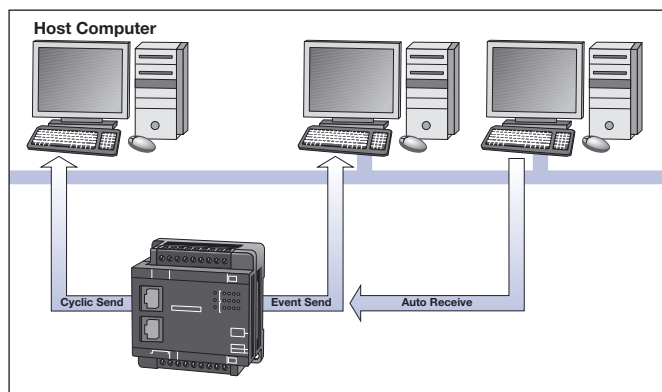

Communication specification

- Connection numbers: Max. 6
- TCP/IP, UDP/IP
- Data send: Event /Cyclic
- Send data numbers: Max. 730 words (WR/WM)
- Receive data numbers: Max. 730 words (WR/WM)

Network Communications Function

The I/O of the Web Controller can be read/written by any PC through the network. HMI ⁽⁴⁾/SCADA ⁽⁵⁾ systems supporting the Ethernet protocol of the Hitachi PLC can be used with the Web Controller.

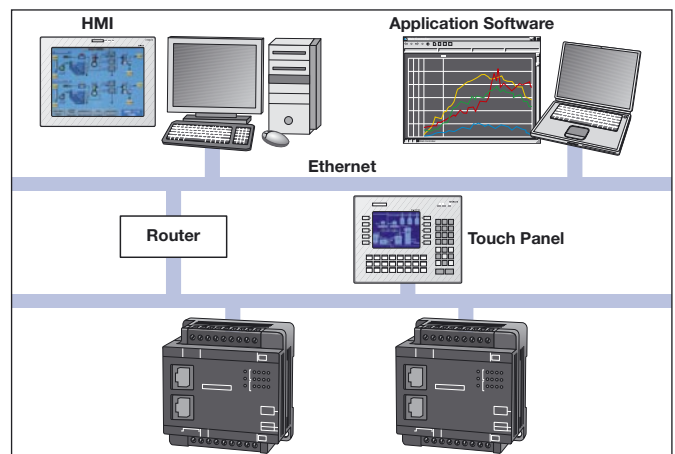

The communication specification

- The number of the connections: Max. 4
 - TCP/IP, UDP/IP
- ⁽⁴⁾ HMI: Human Machine Interface
⁽⁵⁾ SCADA: Supervisory Control And Data Acquisition

Hitachi PLC Network Connection Interface

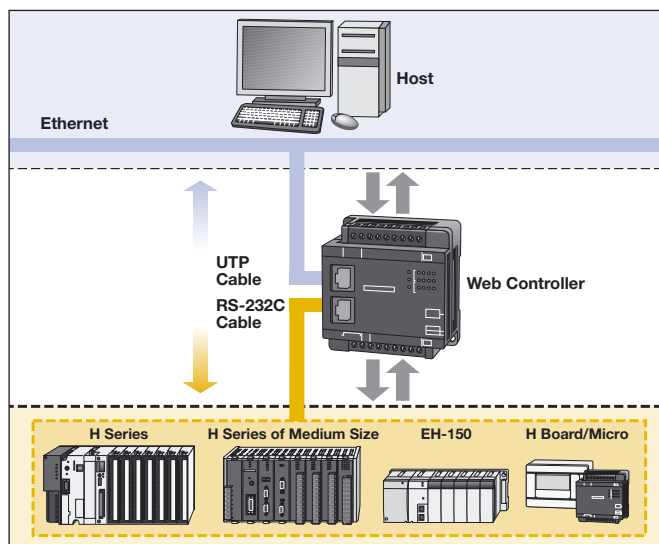

The RS-232C port of the Web Controller supports the Hitachi PLC protocol, any data in an existing Hitachi PLC can be read and written.

The Web Controller can be a gateway module to an Ethernet network for PLC's without the Ethernet Function.

This interface will be useful when ...

- existing system should not be changed.
- existing PLC doesn't have any free slot for Ethernet™ module.
- existing PLC doesn't have any Ethernet™ communication module.

Web Controller EH-WD10DR/WA23DR

Palm sized All-in-One Controller

All features at a glance

Model		EH-WD10DR	EH-WA23DR	
Power supply voltage		24V DC	100/110/120 VAC (50/60Hz) 200/220/240 VAC (50/60Hz)	
Current consumption		0.15A	0.4 A (100 VAC) 0.2A (264 VAC)	
Control	CPU	32 bit-RISC-processor		
	Processing system	Stored program cyclic system		
	Processing speed	Basic instructions: 2.5 µs Application instructions: Several 10 µs		
	Timer/Counter	256 points (TD+CU)		
Memory	Time data	SNTP (Simple Network Time Protocol)		
	User Program	3k steps maximum	max. 32kByte	
	Data	Bit 1,984 points (R) Word 16,384 words (WR) Bit/word shared 16,384 points / 1,024 words (M/WM)	50,176 words (WR)	
	Web page	16kbyte x8, 8kbyte x16, 4kbyte x16	Variable 1 - 64 kByte (in total 320kByte)	
Input	Digital inputs	24V DC 6 points	24V DC 13 points	
	Analogue inputs	-	2ch (0-10V or 0-20mA)	
Output	Digital outputs	Relay 4 points	Relay 10 points	
	Analogue outputs	-	1ch (0-10V or 0-20mA)	
Communication	Max. number of expansion units	not available	4	
	Ethernet	10BASE-T 1ch (RJ-45)	10BASE-T/100BASE-TX 1ch (RJ-45)	
Ethernet communication specifications	Serial	RS-232C 1ch (RJ-45)	RS-232C, RS-422/485 1ch (RJ-45)	
	Communication protocol		Hitachi PLC Ethernet HiProtocol (Command, Slave) Cyclic/Event sending, Auto receiving	
	E-mail sending	Protocol	SMTP	
		User certification	POP-before-SMTP (selectable)	
		Sending conditions	up to 16	
		Destination address	up to 8 for each condition	
	Web server	Send text	256 characters maximum	
		HTTP version	1.0	
	Serial communication specifications	Active-HiProtocol	Function	Monitor and set I/O
			Protocol	Hitachi PLC HiProtocol (Command, Master)
Supported PLC			Hitachi H series/Hitachi EH series H-20/28/40/64, H-200/250/252 H-300/700/2000 H-302/702/1002/2002/4010 EH-150, Micro-EH	
Communication speed			Auto-detection with matching connected PLC	
Passive-HiProtocol		Data size	Read: Max.120 words, Write: Max.100 words	
		Protocol	Hitachi PLC HiProtocol (Command, Slave)	
General Communication		Connected devices	HMI/products supported Hitachi H/EH PLC	
		Protocol	Communication by ladder commands (TRNS0/RECV0) TRNS0: only sending, receiving after sending RECV0: only receiving, sending after receiving	
		Communication speed	300 to 57,600bps	
		Data size	Max. 1,024 bytes (each sending and receiving)	
Mounting		DIN rail or wall mounting		

EH-WD10DR Dimensions

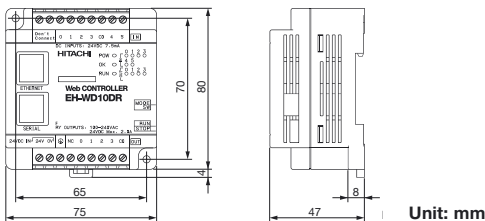

EH-WA23DR Dimensions

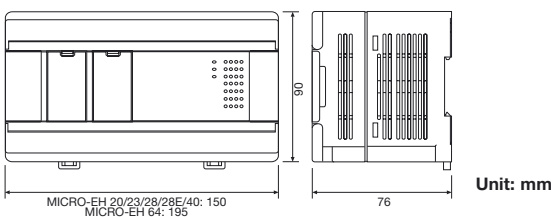

Software Structure

Newly developed "Sporadic Server Method" allows the Web Controller to switch between the Ethernet communication process and the PLC engine process, without losing data integrity.

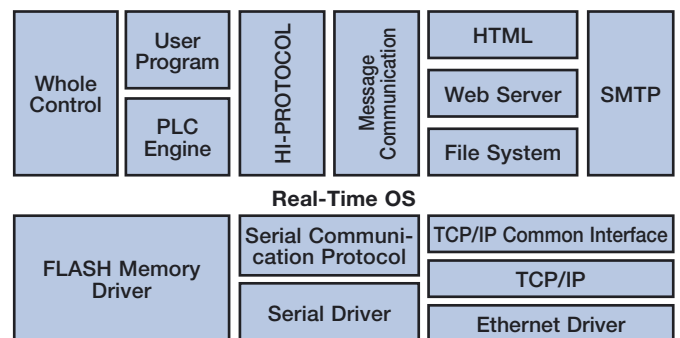

Hitachi Europe GmbH

Am Seestern 18 · D-40547 Düsseldorf
Tel. +49-211-52 83 -0 · Fax +49-211-52 83 -649
Internet: www.hitachi-ds.com
E-Mail: info@hitachi-ds.com