

Next generation industrial controller





HX Series – IoT Enabled

The new Hitachi HX series PAC Controller combines powerful features and efficiency to meet the demands of a global supply chain in manufacturing industries. In addition, HX series is already prepared for the next generation requirements in automation thanks to its IoT capabilities. Manufacturing & service innovations can be achieved with integrated functions and seamless connectivity from field machine level to cloud services.

Open standards

The Hitachi HX Series supports global manufacturing by standardized programming with 5 programming languages compatible with the IEC61131-3 international standard. The integrated EtherCAT master function (industrial open network) enables interconnection of a wide range of devices. Seamless data transfer from field level to cloud is achieved via OPC-Unified Architecture.

Improved processing speed

Through the effective combination of the recently developed high-performance CPU with CODESYS software, Hitachi provides sequential control (logic) and motion control on one CPU platform with very fast execution speed.

Simple & easy design environment

Next generation HX Series models are designed to provide the functionality as PAC Controller (Programmable Automation Controller) which is considered as evolution of both PLC & IPC. This enables users to achieve lower TCO (Total cost of ownership) through space reduction, lower installation, development and maintenance costs.

COMMUNICATION MOTION CONTROL SEQUENTIAL CONTROL

Integrated network communication and core controls required for automated machines & production facilities

- Compatibility with IEC61131-3
- Local data logging by transmitting data to SD memory
- OPC-UA ERP coordination, MES connection, SCADA system
- Information system Ethernet (TCP/IP), IP communication, web supports
- EtherCAT motion control (Multi axes I/O control via EtherCAT)
- Supporting field networks*

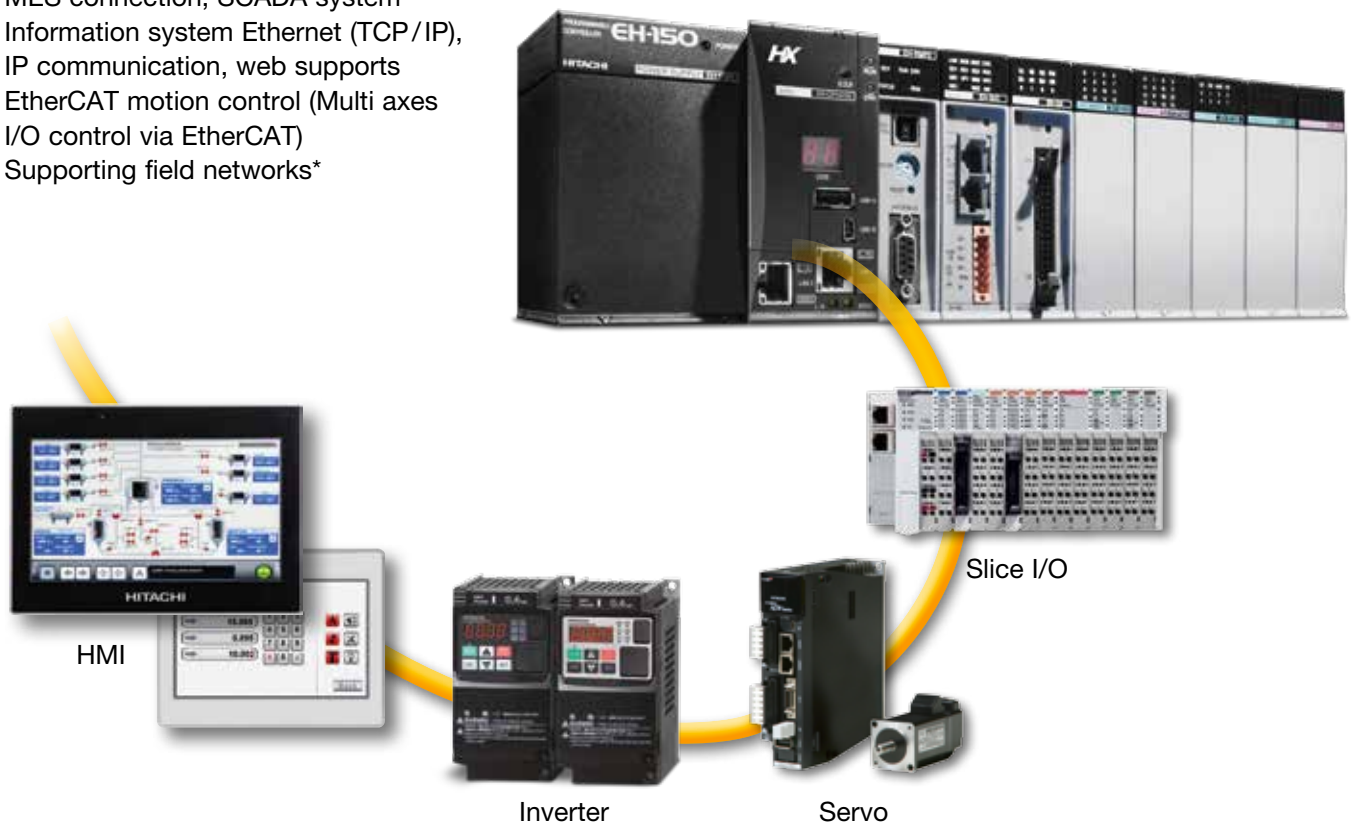

*Some network requires combination use with master module.



General Overview

Flexible expansion

The functionality of the HX CPU can be expanded by adding various modules.

- Digital I/O
- Analogue I/O
- Special Function Modules



Max. 5 expansion bases
 Max. I/O No. 4,224 I/O points
 Max. 66 I/O module
 are possible to connect



Additional I/O expansion can be achieved by attaching EtherCAT slave I/O (max. 255 sets)



Model Line-up

	Physical features				Functional features		
Standard Model	Programming, Data memory 8MB	Ethernet Ports 2	USB		EtherCAT Master		
Full Function Model	Programming, Data memory 16MB	Ethernet Ports 3	USB SD	Serial comm. RS-485	EtherCAT Master		
Motion Model	Programming, Data memory 8MB	Ethernet Ports 2	USB		EtherCAT Master	Soft Motion	
CNC Motion Model	Programming, Data memory 16MB	Ethernet Ports 3	USB SD	Serial comm. RS-485	EtherCAT Master	Soft Motion	CNC (G code)
Redundant Model	Programming, Data memory 16MB	Ethernet Ports 3	USB SD	Serial comm. RS-485	EtherCAT Master	CPU Redundancy	

Specifications of Standard Features

Item	Standard Model HX-CP1S08	Full Function Model HX-CP1H16	Motion Model HX-CP1S08M	CNC Motion Model HX-CP1H16M	Redundant Model HX-CP1H16R	
User program memory	8 MB	16 MB	8 MB		16 MB	
Data memory (non-retain)	8 MB	16 MB	8 MB		16 MB	
Data memory (retain)	0.5 MB					
Max. number of expansion bases	5					
Available expansion cables	0.5 m, 1 m, 2 m					
Max. expansion distance	Max. 2 m between bases, total max. 8 m					
Max. number of I/O modules per base	Max. 11 (excl. power supply module and CPU module)					
Maximum I/O (using 64 point I/O module)	4,224 I/Os					
Processing time	Bit operation (min.)	1.0 ns				
	Double-precision floating point (min.)	6.6 ns				
Programming languages	IEC61131-3 compliant 5 languages (LD/FBD/SFC/IL/ST) + CFC (Continuous Function Chart)					
I/O updating cycle	Refresh processing					
Available features	OPC-UA	✓	✓	✓	✓	✓
	Web visualization	–	✓	–	✓	✓
	NTP (network time protocol)	✓	✓	✓	✓	✓
	FTP Server	✓	✓	✓	✓	✓
	EtherCAT Master	✓	✓	✓	✓	✓
	(communication cycle)	min. 1ms				
	Modbus-TCP Client	✓	✓	✓	✓	✓
	Modbus-TCP Server	✓	✓	✓	✓	✓
	Modbus-RTU Master	✓*	✓	✓*	✓	✓
	Modbus-RTU Slave	✓*	✓	✓*	✓	✓
	SoftMotion (PLCopen compliant + CAM editor)	–	–	✓	✓	–
	CNC (G code)	–	–	–	✓	–
	CPU redundancy	–	–	–	–	✓
Standard input output interface	Ethernet port	2 ports	3 ports	2 ports	3 ports	
	SD memory card slot	–	✓	–	✓	✓
	RS-485 Serial comm. port	–	✓	–	✓	✓
	USB host (USB Memory)	✓	✓	✓	✓	✓
	USB device (CODESYS protocol)	✓	✓	✓	✓	✓
Realtime clock	Built-in RTC (deviation ±60 s/month at 25 °C)					
Battery (option for RTC)	HX-BAT (for RTC)					
Maintenance functions	Self-diagnosis (CPU error, Watch-dog timer error, Memory/Battery error, etc.)					

*EH-SIO serial module required



Standard Features of all Models

Less maintenance costs

■ Battery-less design

Non-volatile memory is used for programming memory & data memory. The CPU can record manufacturing data without optional batteries to protect the data from sudden power failures.

■ Fan-less design

The CPU has no mechanical parts which need to be replaced.

Less costs for software development

- CODESYS – globally accepted, standardized programming software
- Easy to use for PLC beginners, computer system engineers etc.
- Variable names can be commonly used between PLC, HMI and SCADA



Data Protection

■ Block unauthorized access

- Detect/Protect unauthorized external access
- Block unauthorized remote login connection
- Prevent malicious data hacking

■ Control user access

- Login authentication
- User & group control
- Setting access authority

Online user registration



Access permission

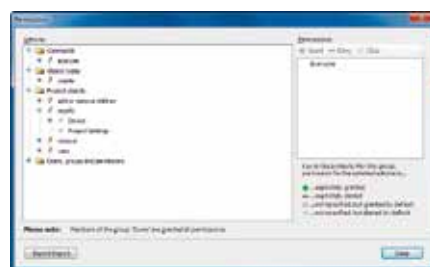

User management



5 programming languages

- Advanced programming visualization (easy to read & understand)
- Flexible memory allocation (no need to allocate work memory address)
- Optimal language selection based on process requirements possible
- Library function which enables easy re-use of user programs

Ladder Logic Diagram (LD)

Recommended for interlock processing.

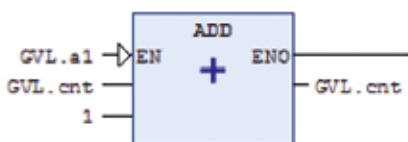
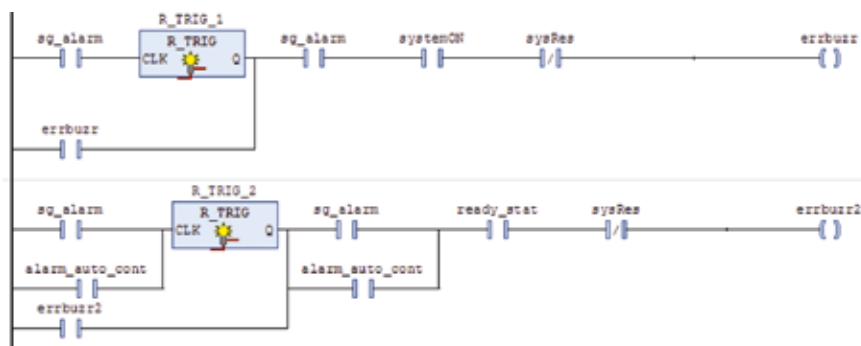

Function Block Diagram (FBD)

Graphical language easy to track command & data transfer between each function.

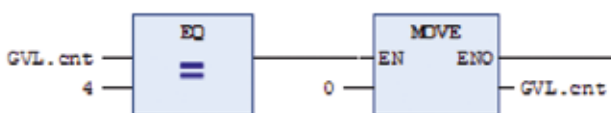

Structured Text (ST)

Ideal for programs having branch, repeat and calculation processes.

```

1 count_M3:=count_M3+1;
2 L2_wait_time (IN:=FALSE, PT:=T#3.6S);
3 L2_wait_time (IN:=TRUE);
4 FOR i:=0 TO count_T DO
5     Kl_temp[1]:=B1_init; //Reset B1
6 END_FOR
7 IF count_Mmax <24 THEN
8     WHILE vxcount<10 DO
9         Timax:=125; //Max.=125 digC
10        END_WHILE
11 END_IF
12 B100status:=FALSE; //B100 complete

```

Instruction List (IL)

Memonic language. Best for the use of short programs and high speed calculation.

```

LD      sg_alarm
OR      TON_1.Q
ANDN   doorclose
AND     alw_d_open
)
AND     ready_start
OR      lampcheck
ST      spare5
CAL     R_TRIG_1(
        CLK:= sg_alarm)
LD      R_TRIG_1.Q
OR      errbuzz
AND     sg_alarm

```

Sequential Function Chart (SFC)

Easy to show state transition.

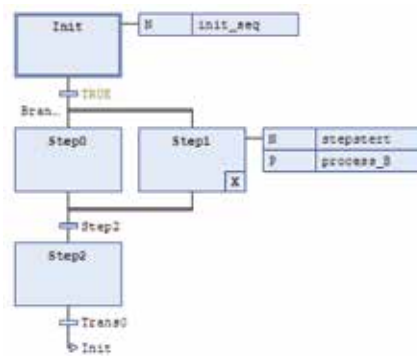



Features of Full Function Model



Large size data logging (SD Card)

Removable SD Card provides a secure and simple way to maintain large data volumes for data logging up to 32 GB.

Web visualisation (Monitoring via Web Browser)

Easy remote access to the controller's web server to monitor the application status without preparing a customized HMI. Potential cost reduction for hardware and on site resources through off site monitoring.

- Web server function prepared as standard
- No requirement of customized HMI
- Availability of monitoring via standard web browser
- Remote maintenance, diagnosis and control can be also achieved

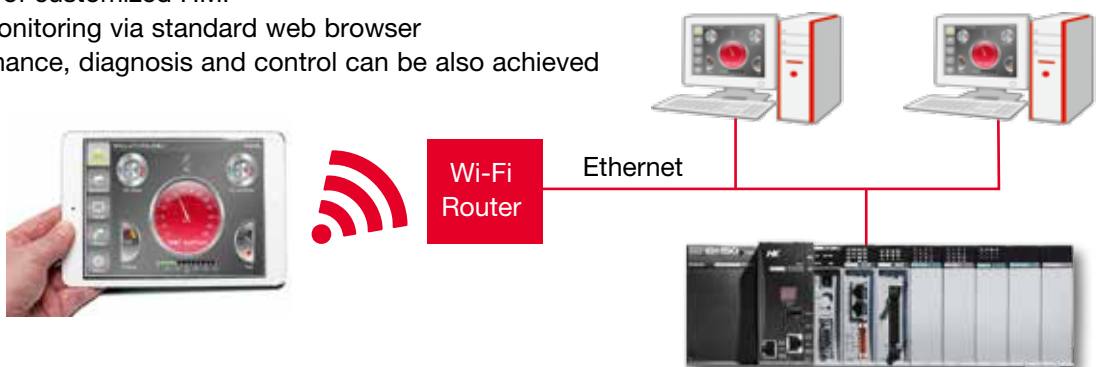



3 Ethernet ports as standard

- Various communication modes between master, controller and slave units by one CPU
- Depending on its connection combination, various topologies are possible

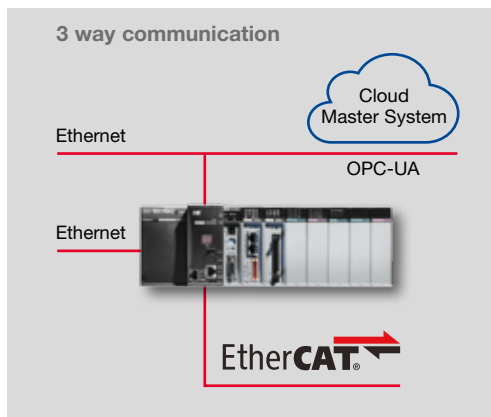

Full Function Model/Motion

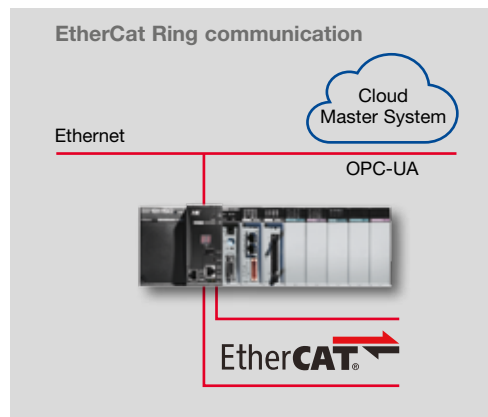

Full Function Model

Redundant Model

HX-CP1H16R

- CPU redundancy by direct Ethernet based connection between 2 redundant CPU's
- Applications which require high availability can be realized
- Local and remote I/O can be used and will be controlled by the active CPU
- Continuous checking of active and stand-by CPU
- Additional 2 LAN ports are available for general purpose such as EtherCAT or communication to OPC clients

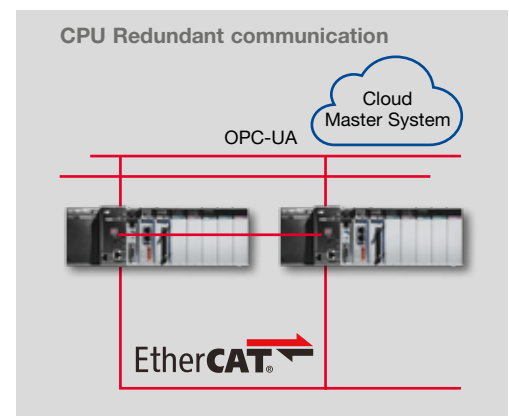

Redundant Model



Motion Model HX-CP1S08M

CNC Motion Model HX-CP1H16M

PLCopen based Motion control function block

- Position, velocity & acceleration control for simple single axis or for synchronized control of multiple axes, using graphical editor prepared for electronic cam function
- Motion simulation with a virtual axis function
- Motion and logic on one CPU
- LAN port supports motion functionality
- A variety of slaves such as inverters or remote I/O may be controlled via EtherCAT
- On CNC Motion Model, a SoftMotion CNC package is available with multi axes coordinated functions for CNC & robots



EtherCAT®



Servo



Compact I/O



Inverter



Slice I/O



Function blocks for PLCopen based motion control

In addition to PTP position control in single axis use, interpolation and synchronized control of multiple axes, the HX Series enables speed and torque control in combination with feedback data.



Motion control applicable for PLCopen standard Single Axis Part I and II Master/Slave Axis (e.g. MC_CamIn, MC_GearIn, MC_Phasing etc.)

CAM editor

- Create cam table using the CAM editor

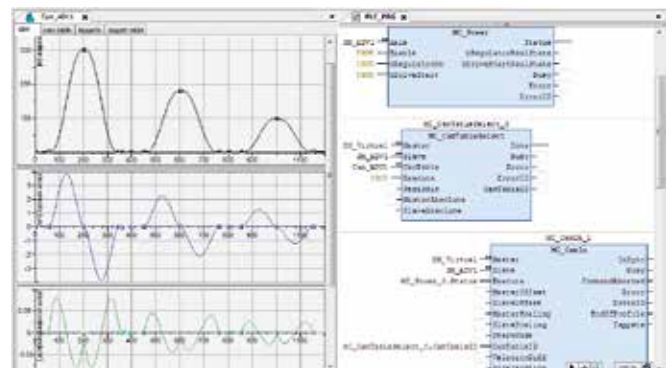

CNC (G code), available on CNC Motion Model only

- Trajectory control by G code. Possible to read out coordinates from DXF files. Examples: X-Y table, Multiple joint robots, Tripod robots

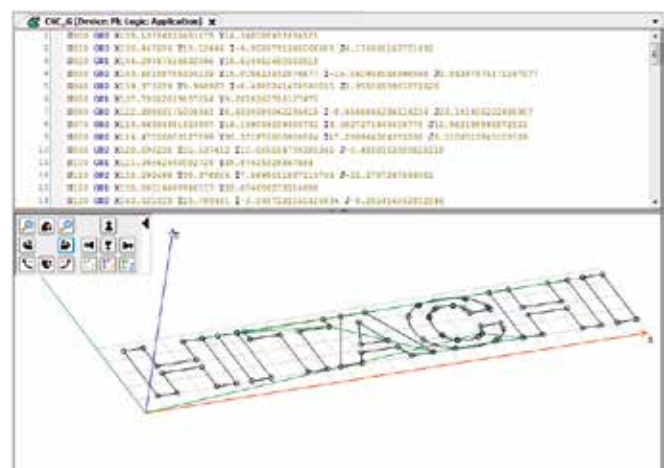

HX Series Module List

Item	Model	Specification
Power supply modules	HX-PSA	AC power supply 100–240V, output DC 5V, 3.8A, external DC 24V, 0.4A
	HX-PSD	DC power supply 24V, output DC 5V, 4A, 24V – 0.2A
Base racks	EH-BS3A	Base / Expansion rack with 3 I/O slots
	EH-BS5A	Base / Expansion rack with 5 I/O slots
	EH-BS6A	Base / Expansion rack with 6 I/O slots
	EH-BS8A	Base / Expansion rack with 8 I/O slots
	EH-BS11A	Base / Expansion rack with 11 I/O slots
Input modules	EH-XD8	8 points, DC 24V input, removable terminal block
	EH-XD16	16 points, DC 24V input, removable terminal block
	EH-XD32	32 points, DC 24V input, connector type
	EH-XD32E	32 points, DC 24V input, removable spring type terminal block
	EH-XD64	64 points, DC 24V input, connector type
	EH-XA16	16 points, AC 100–120V input, removable terminal block
	EH-XAH16	16 points, AC 200–240V input, removable terminal block
Output modules	EH-YT8	8 points, transistor output, DC 12/24V, sink type, removable terminal block
	EH-YT16	16 points, transistor output, DC 12/24V, sink type, removable terminal block
	EH-YT32	32 points, transistor output, DC 12/24V, sink type, connector type
	EH-YT32E	32 points, transistor output, DC 12/24V, sink type, removable spring type terminal block
	EH-YT64	64 points, transistor output, DC 12/24V, sink type, connector type
	EH-YTP8	8 points, transistor output, DC 12/24V, source type, removable terminal block
	EH-YTP16	16 points, transistor output, DC 12/24V, source type, removable terminal block
	EH-YTP16S	16 points, transistor output, DC 12/24V, source type, short circuit protection, removable terminal block
	EH-YTP32	32 points, transistor output, DC 12/24V, source type, connector type
	EH-YTP32E	32 points, transistor output, DC 12/24V, source type, removable spring type terminal block
	EH-YTP64	64 points, transistor output, DC 12/24V, source type, connector type
	EH-YR8B	8 points, individual relay output, AC 100/240V, DC 24V, removable terminal block
	EH-YR12	12 points, relay output, AC 100/240V, DC 24V, removable terminal block
	EH-YR16	16 points, relay output, AC 100/240V, DC 24V, 16 points/1common, removable terminal block
	EH-YS16	16 points, triac output, AC 100/240V, removable terminal block

Item	Model	Specification
Analogue input modules	EH-AX44	12 bit analogue input, 4–20 mA, voltage 0–10V, each 4 channel
	EH-AX8V	12 bit analogue input 8 ch., voltage 0 to +10V
	EH-AX8H	12 bit analogue input 8 ch., voltage –10 to +10V
	EH-AX8I	12 bit analogue input 8 ch., current 4–20 mA
	EH-AX8IO	12 bit analogue input 8 ch., current 0–22 mA
	EH-AXH8M	14 bit analogue input 8 channel, 0–22 mA, 4–22 mA, –10 to +10V, 0 to 10V
	EH-AXG5M	Insulation, 16 bit analogue input 5 channel, 0–22 mA, 4–22 mA, –10 to +10V, 0 to 10V
	EH-PT4	4 channel RTD (Pt 100/Pt 1000) input, signed 15 bit
	EH-RTD8	8/6 channel RTD (Pt 100/Pt 1000) input, signed 15 bit
	EH-TC8	8 channel thermocouple input module (K, E, J, T, B, R, S, N), signed 15 bit
Analogue output modules	EH-AY22	12 bit analogue output, 4–20 mA, 0 to 10V, each 2 channel
	EH-AY2H	12 bit analogue output 2 channel, voltage –10 to +10V
	EH-AY4V	12 bit analogue output 4 channel, voltage 0 to +10V
	EH-AY4H	12 bit analogue output 4 channel, voltage –10 to +10V
	EH-AY4I	12 bit analogue output 4 channel, current 4–20 mA
	EH-AYH8M	14 bit analogue output 8 channel, 0–22 mA, 4–22 mA, 0 to 10V
EH-AYG4M	Insulation, 16 bit analogue output 4 channel, 0–22 mA, 4–22 mA, –10 to +10V, 0 to 10V	
Counter modules	EH-CU	2channel high speed counter input, max frequency 100 kHz 1/2 phase switchable, 4-point open collector output
	EH-CUE	1channel high speed counter input, max. frequency 100 kHz 1/2 phase switchable, 2-point open collector output
Positioning module	EH-POS	1axis pulse positioning module, 400k pulse / second
Communication modules	EH-SIO	Serial communication module (RS-232C / RS-422 / 485, Modbus protocol)
	EH-RMP2	Profibus-DP master module
	EH-RMD2	DeviceNet scanner module
Dummy module	EH-LNK	CPU link module, coaxial cable
	EH-DUM	Module for open slots

Hitachi Europe GmbH, Am Seestern 18, D-40547 Düsseldorf
 Phone: +49(0)211-5283-0, Fax: +49(0)211-5283-649
www.hitachi-industrial.eu, info@hitachi-ds.com
 © Hitachi Industrial Equipment Systems Co., Ltd., Japan

All company and product names in this brochure are the property of the respective companies.
 Subject to modification/change without notice/errors and omissions excepted (E & OE).